

élantec

As the bandwidth of op-amps today pushes past 100MHz towards the GHz region, increasing attention must be paid to the components, loads, and circuit traces which surround the op-amp. Not only is this necessary to optimize performance, but neglecting to do so may throw the amplifier into oscillation. This application note discusses the effect of loads, especially capacitive ones, on the behavior of a high speed op-amp.

Real World Loads

To start, one needs to question whether there are any pure capacitive loads at high frequencies. To connect any load we need some wires or metal interconnect, and associated with these wires are resistance and self-inductance. In the following sections we will examine some possible loads and their behavior over frequency.

Coaxial Cables

Coaxial cables must be terminated in the proper impedance to look like a resistive load to the driving source. A common myth is that an unterminated cable looks capacitive. While this may be true for short cables at low frequencies, it certainly does not hold at higher frequencies. An unterminated cable presents a varying impedance to the source over frequency, and it can look capacitive or inductive depending on the length of the cable and the frequency. This behavior can be explained by viewing the coaxial cable as a lossless transmission line. The input impedance Z_i of a transmission line with characteristic impedance Z_0 and length L , terminated in a load Z_L , is given by:

$$Z_i = Z_0 \frac{Z_L + jZ_0 \cdot \tan \beta L}{Z_0 + jZ_L \cdot \tan \beta L}$$

where $\beta = 2\pi/\lambda$, and λ is the size of one wavelength on the line. As an example, consider the standard RG58C/U 50Ω coaxial cable. If we terminate the cable with a 50Ω load, then by the above equation $Z_i = Z_0$ and the cable should look perfectly resistive over frequency. Figure 1A shows an actual measurement done on a 5' long cable terminated in a 50Ω load. Except for minor impedance variations due to mismatch and line loss, the cable does look like 50Ω over a widerange of frequency. If the cable was terminated improperly, with a 75Ω load for example, the impedance then varies with frequency as shown in Figure 1B. Note that even though we have terminated the cable with a resistive load, the cable impedance phase varies between $\pm 23^\circ$. In the extreme, if the cable is unterminated, then $Z_L = \infty$ and the equation reduces to $Z_i = -jZ_0/(\tan \beta L)$. Figure 1C shows the input impedance of an unterminated 50Ω cable, and we see the phase skipping between -90° (capacitive) to $+90^\circ$ (inductive) at regular intervals. In fact, for frequencies at

which the line length is an odd multiple of a quarter wavelength, Z_i becomes zero. Conversely, for frequencies at which the line is a multiple of a half wavelength, Z_i becomes infinite.

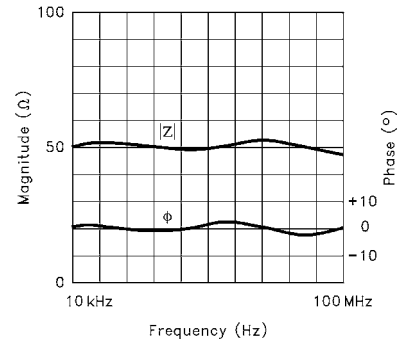

FIGURE 1A. IMPEDANCE OF A 50Ω CABLE TERMINATED IN 50Ω

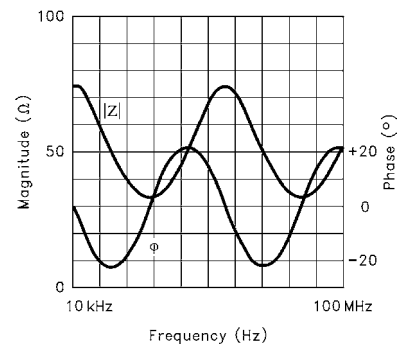

FIGURE 1B. IMPEDANCE OF A 50Ω CABLE TERMINATED IN 75Ω

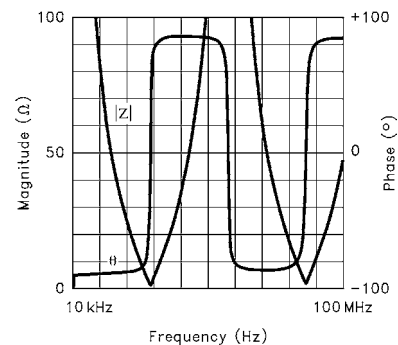

FIGURE 1C. IMPEDANCE OF AN UNTERMINATED IN 50Ω CABLE

The moral of the story is that you must terminate your cable with the correct load at high frequencies. Otherwise, the

driving source will see a wildly changing load with frequency, and this may cause the amplifier to oscillate.

Discrete Capacitors

At high frequencies, another parasitic which becomes dominant is the inductance of a leaded capacitor. We can treat the capacitor as a series RLC circuit, with L modeling the lead inductance and R modeling the losses due to the electrodes, leads, and dielectric. The capacitor will thus self-resonate at a frequency given by:

$$f_o = \frac{1}{2\pi\sqrt{LC}}$$

As an example, the impedance of a 10nF leaded ceramic capacitor was measured, yielding the equivalent series RLC values of 0.66Ω, 36nH, and 8.6nF respectively. Figure 1D shows the impedance of this capacitor over frequency, and we see that it self-resonates at 9.1MHz, behaving as an inductor for frequencies above that. For this measurement the leads of the capacitor were kept as short as possible. If we were a bit sloppy and left 1 lead on the capacitor, the inductance would increase to about 60nH, lowering the resonance down to 7MHz. Generally, an inch of slender wire has about 20nH of inductance per inch, which is why it is so important in high frequency work to minimize lead length.

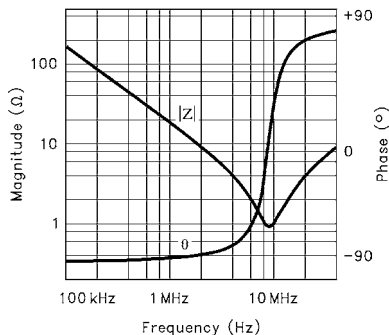
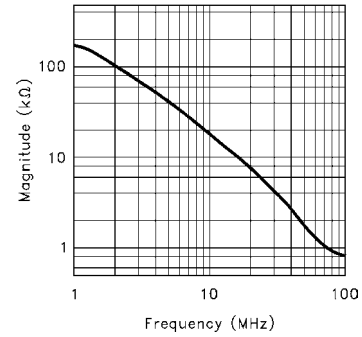

FIGURE 1D. IMPEDANCE OF A LEADER 10nF CAPACITOR

Inputs of Active Devices

Besides driving cables or passive loads, an amplifier could also be driving the input of another active device. At first, one might think that the input of an op-amp can be modeled by some high-value resistance in parallel with a capacitance. While this model is correct to some extent, some measurements quickly reveal that the input capacitance is not all that “pure”. Figure 1E shows the input impedance of the EL2044 connected as an unity gain buffer. While the impedance does decrease with frequency, it does not do so at -6dB/octave; rather, the impedance is decreasing at a greater rate. The phase of the input impedance also reveals the “impurity” of this input capacitance.



(a) MAGNITUDE

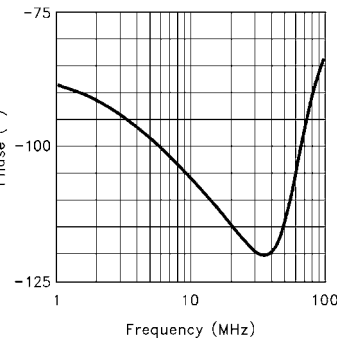

(b) PHASE

FIGURE 1E. INPUT IMPEDANCE OF A UNITY GAIN FOLLOWER USING THE EL2044

Other Capacitive Loads

As the examples above may suggest, strictly capacitive loads are difficult to find at high frequencies. The only load we know of that is capacitive at high frequencies is a Liquid Crystal Display (LCD). In this instance, the intersection of the row and column lines causes many capacitances to be distributed along the line, and because of numerous parallel lines the inductance tends to be low, giving loads upwards of 1000pF without large amounts of inductance.

Although pure capacitive loads are rare at high frequencies, this does not mean that we can ignore them. Capacitive reactance can exist over narrow frequency ranges, and we must ensure that our amplifier does not oscillate in these ranges.

Capacitive Loads are Hard

Generally, an op-amp has no problem driving resistive or inductive loads. Of course, this statement needs to be qualified as to the size of the load, but the point is that both kinds of loads do not degrade the phase margin of the amplifier. Capacitive loads, on the other hand, do reduce an amplifier’s phase margin, and in severe cases can cause the op-amp to oscillate.

Op-Amp Output Resistance

To see how various loads affect the phase margin, we can model the open-loop output impedance of an op-amp as the resistance R_O . Shown in Figure 2A, R_O forms a divider with the load Z_L , and the output V_O goes to the feedback network R_F and R_G . If the phase lag of V_O increased due to the $R_O Z_L$ divider, the phase margin around the loop diminishes and peaking, even oscillation, will occur.

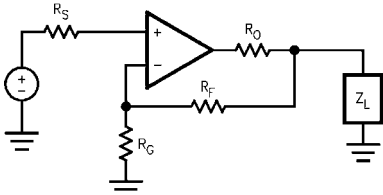

FIGURE 2A. OPEN LOOP OUTPUT RESISTANCE OF AN OP-AMP

First, if Z_L is resistive, then there is no phase lag and the phase margin is preserved. If Z_L is inductive, then V_O gets a phase lead and the phase margin is increased! Finally, if Z_L is capacitive then we do get a phase lag and the amplifier will peak due to this load. The severity of this problem increases with high speed op-amps, as the example below illustrates.

Suppose that we have a 100MHz amplifier with 45° of phase margin. Let $R_O = 50\Omega$ and $Z_L = 15pF$, then this network has a cutoff frequency f_C of 212MHz. At 100MHz, this network provides 25° of phase lag and thus reduces the phase margin to 20°. Severe peaking will result in the frequency response. The loss of phase margin due to a capacitive load is given by:

$$\Delta PM = \text{TAN}^{-1} \frac{f}{f_C}$$

where f_U is the op-amp's unity gain frequency, and f_C is the cutoff frequency of the $R_O C_L$ network. Thus we see that for high frequency op-amps, even a small capacitive load can cause a large reduction in the phase margin.

Op-Amp Output Inductance

Another way to understand an op-amp's sensitivity to capacitive loads is to look at its closed-loop output impedance more closely. As an example, consider the output impedance vs frequency curve of the EL2044, reproduced in Figure 2B. We see that beyond about 200kHz, the output impedance actually looks inductive, and this would resonate with a capacitive load! To see why an op-amp's output impedance looks inductive, consider the circuit in Figure 2C, where we have an op-amp with open loop gain

$A(s)$ and some general feedback network with gain β . The transfer function of this circuit is given by:

$$H(s) = \frac{A(s)}{1 + A(s)\beta}$$

If the loop transmission $A(s)\beta$ is large, then $H(s) \approx 1/\beta$, and we arrive at one of the important results of negative feedback: the system's gain depends largely on the feedback network and not on the op-amp itself. Similarly, the system's output impedance is given by:

$$Z_{OUT} = \frac{R_O}{1 + A(s)\beta}$$

where R_O is the op-amp's open loop output resistance. Thus for large values of loop transmission, negative feedback drives the output impedance to some low value. As frequency increases, however, the magnitude of $A(s)$ rolls off, reducing the loop transmission and raising Z_{OUT} . Eventually, at frequencies where $A(s)\beta \ll 1$, Z_{OUT} asymptotes to the output impedance of the op-amp output stage.

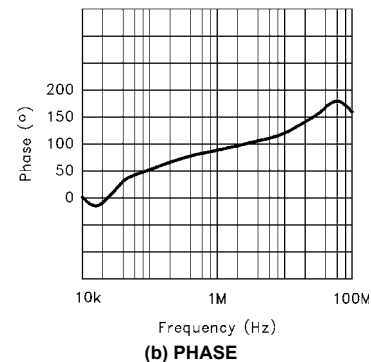
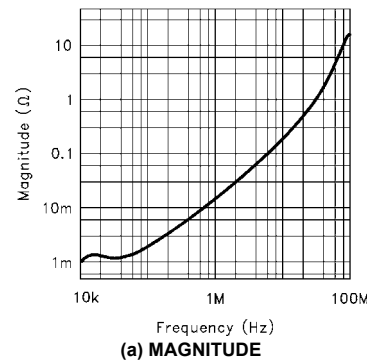

FIGURE 2B. CLOSED LOOP OUTPUT IMPEDANCE OF EL2044

Output Stage Superinductance

Beyond the system level explanations given above, we can gain understanding into the problem by looking at the op-amp at the transistor level. In any op-amp we have an output stage that buffers the gain stage from the external load. The emitter follower is often used for this purpose, so we will consider the follower's output impedance under different

conditions. Figure 2D shows the general circuit. At low frequencies we can find the output impedance using the reflection rule:

$$R_{OUT} = \frac{R}{\beta + 1}$$

At higher frequencies, however, we cannot neglect the frequency dependence of β . If we model β as a single-pole system with DC gain β_0 and unity gain crossing w_U , then the output impedance becomes the following:

$$Z_{OUT} \cong \frac{R}{\left(\frac{\beta_0}{1 + j \frac{f\beta_0}{f_T}} \right)} = \frac{R}{\beta_0} \left(1 + \frac{f\beta_0}{f_T} \right) = \frac{R}{\beta_0} + jf \frac{R}{f_T}$$

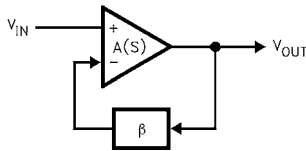

FIGURE 2C. BLOCK DIAGRAM OF GENERAL FEEDBACK SYSTEM

then we get the transformations shown in Figure 2E. In the first case where the source is resistive, the output impedance is resistive and inductive. This is intuitively similar to the op-amp example presented earlier; since β decreases with frequency, R_{OUT} rises and thus appears inductive. Hence we see that even a simple emitter follower can resonate into a capacitive load. As an example, a transistor with an internal base resistance of 200Ω and a f_T of 300MHz has an output inductance of 100nH. If this was

used to drive a 50pF load, its resonant frequency would be at 70MHz, well within the range of today's high speed op-amps.

The next transformation is for a capacitive source, which results in a resistive and capacitive output impedance.

Finally, when the source is inductive, the output impedance has a negative real component. This negative impedance has no reactive phase, but its magnitude increases as the frequency squared; we will name this component a "super-inductor". If the sum of series resistance in a network is negative and all the reactances cancel, then the network will oscillate. Thus the seemingly benign emitter follower really misbehaves if we drive it with an inductive source!

So where do we get an inductive source from within an op-amp? The Darlington connection is one possibility. In this configuration, an emitter follower drives another emitter follower. The first follower transforms its base resistance into an output inductance, and the second follower transforms this inductance into an output super-inductance. The effect is the same for a NPN follower driving a PNP, or vice versa. Since base resistance tends to be larger for IC transistors than for discrete transistors, super-inductance is very much an issue for monolithic amplifiers. An output stage with this topology is shown in Figure 2E, first used in the LH0002 buffer amplifier. Most integrated amplifiers built with a complementary bipolar process also use this output stage, and so a real amplifier's output impedance is the sum of resistive, inductive, and super-inductive components. If a capacitive load resonates with the inductance at a frequency where the super-inductance is greater than the real resistance, oscillations will occur in the output stage independent of loop characteristics.

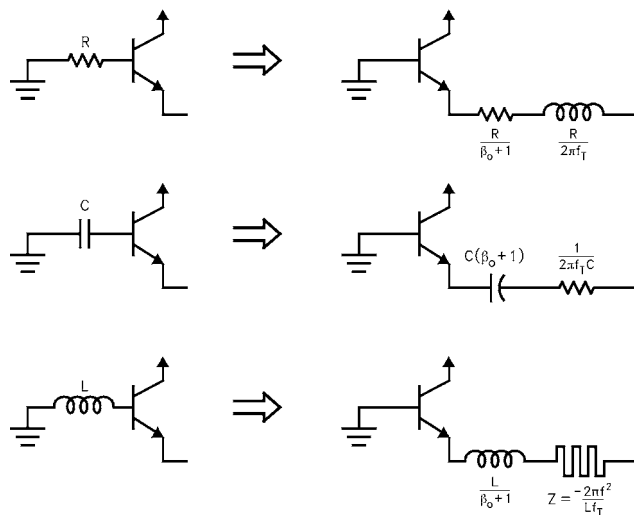

FIGURE 2D. IMPEDANCE TRANSFORMATIONS FOR AN EMITTER FOLLOWER WITH VARIOUS SOURCE IMPEDANCES

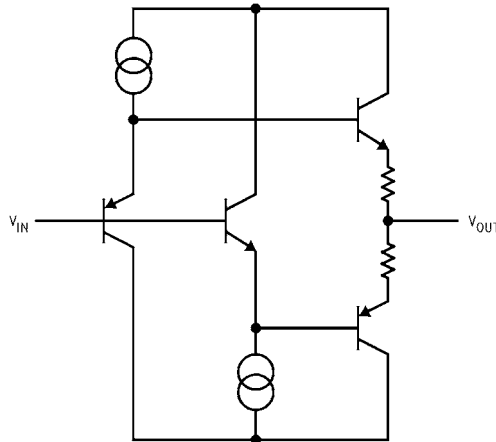

FIGURE 2E. LH0002 OUTPUT STAGE TOPOLOGY

Possible Solutions

Like death and taxes, it is inevitable that we will have to drive some form of capacitance. Unlike death and taxes, techniques exist to deal with capacitive loads to some degree. We will present some of these techniques in the following sections.

Internal Compensation

As we saw earlier, heavy capacitive loads can reduce the phase margin of an amplifier, and thus cause the amplifier response to peak. However, if we can lower the dominant pole of the amplifier such that the phase margin is restored, then the overall amplifier response should not peak, although the bandwidth will also be reduced. Is there such a way of sensing the amount of capacitive load and adjusting the dominant pole appropriately? The answer is yes, and the solution can be seen in Figure 3A, where a capacitor C_C has been connected between the gain stage and output of an op-amp.

First, consider a light load on the output (high R_L , low C_L). Driving this load, the two voltages V_{OUT} and V_{HIZ} should track each other closely, and no current will flow thru the $R_C C_C$ combination. The compensation network does no work in this case, and we get the normal amplifier response as

given by Curve A in Figure 3B. Now suppose we raise C_L to some high value. The voltage V_{OUT} will not follow V_{HIZ} as closely, and current begins to flow in the $R_C C_C$ network.

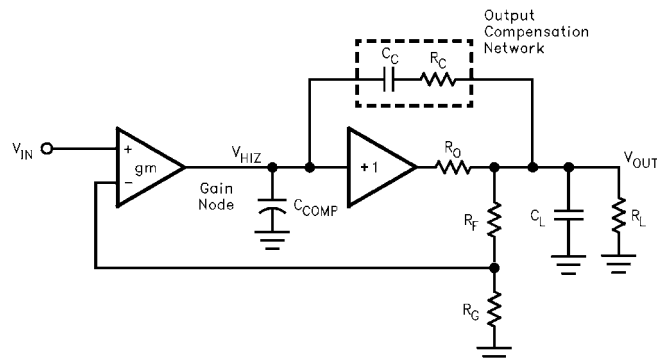

FIGURE 3A. COMPENSATION SCHEME TO MAKE OP-AMPS MORE TOLERANT OF CAPACITIVE LOADS

This in effect puts part of C_C on the gain node, thus lowering the bandwidth of the amplifier. Curve B in Figure 3B shows what the response may look like in this case. On the other hand, Curve C shows what will happen if we did not use the compensation network to drive a large C_L ; although we retain the bandwidth, severe peaking occurs.

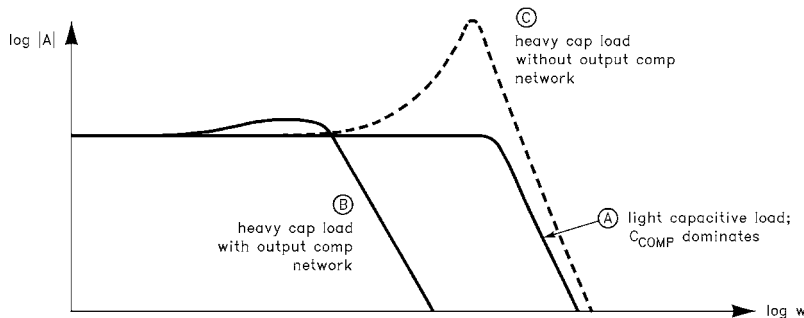

FIGURE 3B. EFFECTS OF COMPENSATION SCHEME SHOWN IN FIGURE 3A

This technique does have its drawback: the bandwidth reduces for heavy loads in general. Thus, the bandwidth lowers for heavy resistive loading as well, which is an undesirable trait. In addition, this technique degrades the RF linearity of the amplifier, ruining such performance parameters as differential gain and phase.

External Compensation—Series Resistor

To avoid sacrificing performance, most of Elantec's op-amps are not heavily compensated for capacitive loads. The use of external compensation networks may be required to optimize certain applications. Figure 3C shows one such network, where we have inserted a series resistor with the op-amp's output. The stabilizing effect of this resistor can be thought of in two ways. One is that R_{SERIES} serves to isolate the op-amp output and feedback network from the capacitive load. The other way to think about it is to recall the super-inductor concept introduced earlier. Since the output stage presents a negative resistance over certain frequencies, adding enough series resistance would cancel this negative resistance and prevent oscillation.

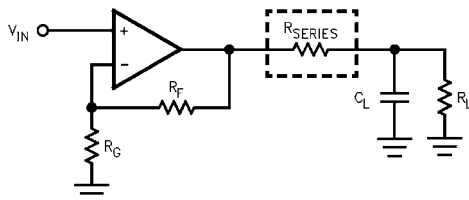

FIGURE 3C. SERIES RESISTOR COMPENSATION TO STABILIZE AN OP-AMP DRIVING CAPACITIVE LOADS

The required amount of series resistance depends on the part used, but values of 5Ω to 15Ω is usually sufficient to prevent local resonances. The disadvantage of this technique is a reduction in gain accuracy, and extra distortion when driving nonlinear loads.

External Compensation—The Snubber

Another way to stabilize an op-amp driving a capacitive load is the use of a snubber, as shown in Figure 3D. To see how a snubber can reduce peaking, consider the 300MHz f_T transistor presented in Section 2. For that example, the output inductance of the emitter follower was shown to be 100nH. With a light resistive load $R_L = 1k\Omega$ and moderate capacitive load $C_L = 50pF$, the circuit resonates at 70MHz with a Q given by:

$$Q = \frac{R_L}{\sqrt{\frac{L}{C_L}}}$$

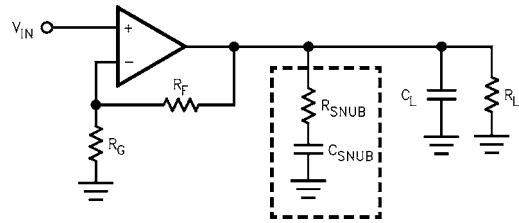

FIGURE 3D. THE SNUBBER

In this case, Q works out to be about 22, giving us severe peaking in the frequency response. However, with a load of 150Ω , the Q reduces to 3. Thus the extra stability gained with a heavy load resistor is desirable, but we may be wasting DC load current with this approach. A way around this is to insert a capacitor in series with the resistor, resulting in a snubber.

There are various ways to determine appropriate values for R_{SNUB} and C_{SNUB} , one of which is presented in [2]. We will describe an alternative method here. First, operate the amplifier as in the intended application and look at its frequency response on a network analyzer. Find the frequency at which the peak occurs, and denote that as f_p . Next, try loading the amplifier with different load resistances until the peaking reduces to a satisfactory level; this value will be R_{SNUB} . Finally, we need a capacitor that will make the snubber look resistive at the frequency of the peak. A rough guideline is to make the snubber zero frequency 3 times lower than f_p , resulting in the following design equation:

$$C_{SNUB} = \frac{3}{2\pi \cdot f_p \cdot R_{SNUB}}$$

Note that as opposed to the series resistor method, the use of a snubber does not degrade the gain accuracy or cause extra distortion when driving a nonlinear load.

Unterminated Coaxial Lines

As we may have hinted earlier, unterminated coaxial lines mean trouble. The simple remedy for this is to terminate the line in its characteristic impedance, and the cable will look like a stable resistive load to the driving amplifier.

In certain cases the cable termination may be unknown, or it may not be under our control at all times. A good example of this is in ATE systems, where an amplifier drives a signal through a coaxial cable to a test pin. However, when a device under test is not plugged in, the test pin is left unterminated, and so the amplifier is driving into an open cable. Figure 3E shows how we can use back-matching to solve this problem. In back-matching, we insert a resistor R_{BM} equal to the cable's characteristic impedance between the amplifier and the cable. R_{BM} serves to isolate the amplifier from the cable, the impedance of which could wildly vary with frequency. Also, since R_{BM} terminates the cable at

the source end, reflected signals are absorbed in R_{BM} , preventing multiple reflections from occurring.

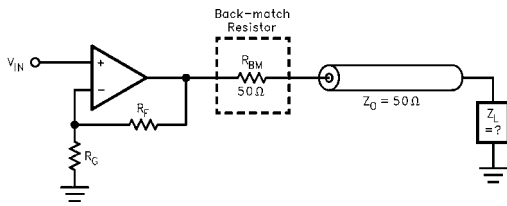

FIGURE 3E. BACKMATCHING

Summary

High frequency op-amps are sensitive to capacitive loads due to the loss of phase margin in driving these loads. In addition, the op-amp output stage can introduce its own resonance, further complicating the stability issue. These problems can introduce severe peaking in the frequency response or excessive ringing in the transient response. Some recent op-amp designs have incorporated an internal compensation network for capacitive loads. Such op-amps, however, sacrifice bandwidth and RF linearity in return for foolproof usage. For the best performance, amplifiers without the internal compensation network should be used in conjunction with a snubber when necessary. Proper bypassing and board layout have not been stressed in this application note, but they are equally important to the well-being of a high speed op-amp.

References

1. Cheng, David K., *Field and Wave Electromagnetics*, Addison-Wesley: New York, 1989.
2. Siegel, Barry. "High Frequency Amplifier Instability". Elantec, October 1992.